

# M.2 (P30)

## 4TE3 series

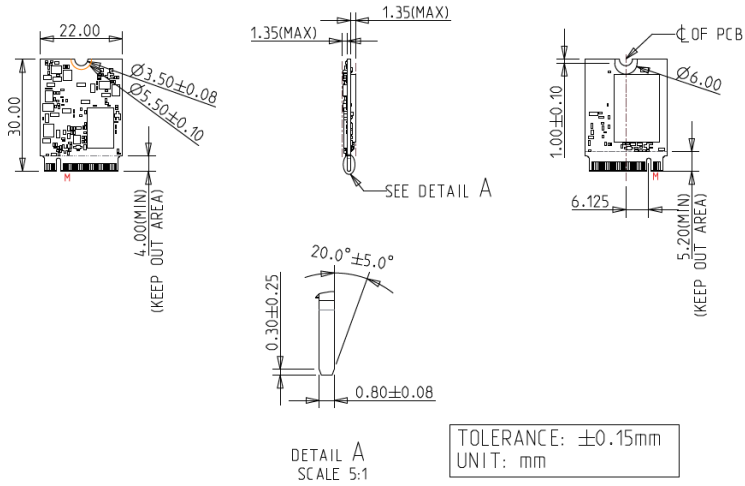

### Diagram (ST)



### Diagram (WT)

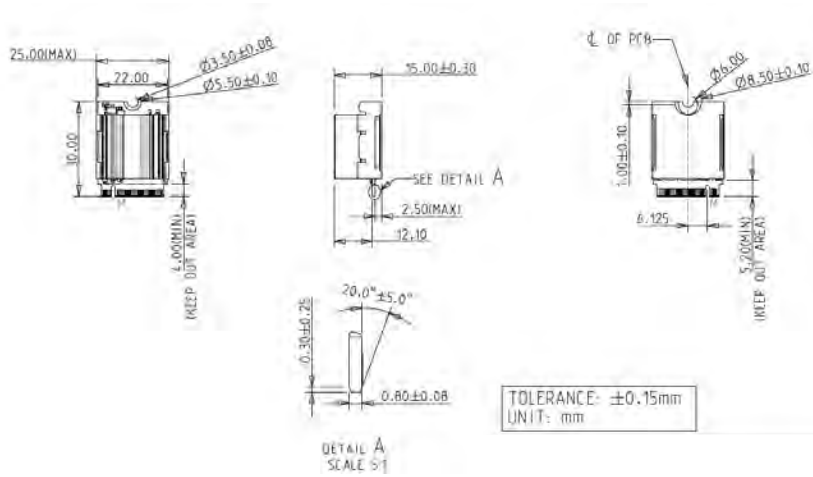

## Specifications

Interface	PCIe Gen4 x2
Flash Type	3D TLC
P/E cycle	3,000
Capacity	128GB~1TB
Max. Channels	2
Sequential R/W (MB/sec, max.)	1,800/1,450
Max. Power Consumption	3.1W
Thermal Sensor	√
External DRAM Buffer	NA
AES	√
TCG Opal	√ (optional)
H/W Write Protect	√ (optional)
ATA Security	√
Dimension (WxLxH)	WT with heatsink: 25.0 X 30.0 X 15.0 mm (Pure M.2: 22.0 X 30.0 X 3.4 mm)
Environment	Vibration: 20G @7~2000Hz Shock: 1500G @ 0.5ms Storage Temperature: -40°C ~ +85°C MTBF: >3,000,000 hour

## Ordering Information

Operation Temp.	128GB	256GB	512GB	1TB
Standard Grade (0°C ~ +70°C)	DEM23-A28DH1KCBDF	DEM23-B56DH1KCBDF	DEM23-C12DH1KCBDF	DEM23-01TDH1KCBDF
Industrial Grade (-40°C ~ +85°C)	DEM23-A28DH1KWBDFFH	DEM23-B56DH1KWBDFFH	DEM23-C12DH1KWBDFFH	DEM23-01TDH1KWBDFFH

For TCG OPAL function, the PN Code 10<sup>th</sup>~12<sup>th</sup> will be DH2.