

SATADOM-ML

3SE3 series

Diagram

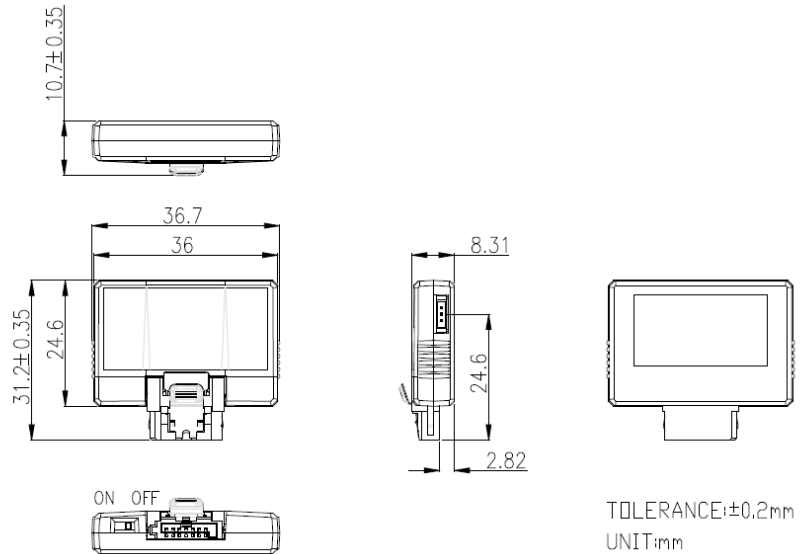

Specifications

Interface	SATA III
Flash Type	SLC
Capacity	4GB~64GB
Max. Channels	4
Sequential R/W (MB/sec, max.)	400/200
Max. Power Consumption	1.1W (5V x 220mA)
Thermal Sensor	ST- Optional/ WT- Default
Extended DRAM buffer	-
H/W Write Protect	√
ATA Security	√
S.M.A.R.T.	√
Dimension (WxLxH)	36.7 X 31.2 X 10.7 mm
Environment	Vibration: 20G @7~2000Hz Shock: 1500G @ 0.5ms Storage Temperature: -55°C ~ +95°C MTBF: 3 million hours

Ordering Information

Operation Temp.	4GB	8GB	16GB	32GB	64GB
Standard Grade (0°C ~ +70°C)	DESML-04GD08SCADB*	DESML-08GD08SCAQB*	DESML-16GD08SCAQB*	DESML-32GD08SCAQB*	DESML-64GD08SCAQB*
Industrial Grade (-40°C ~ +85°C)	DESML-04GD08SWADB*	DESML-08GD08SWAQB*	DESML-16GD08SWAQB*	DESML-32GD08SWAQB*	DESML-64GD08SWAQB*

* = A: Pin8+ power cable

* = B: Pin8+ Pin 7