

# SATADOM-MV

## 3IE4 series

### Diagram

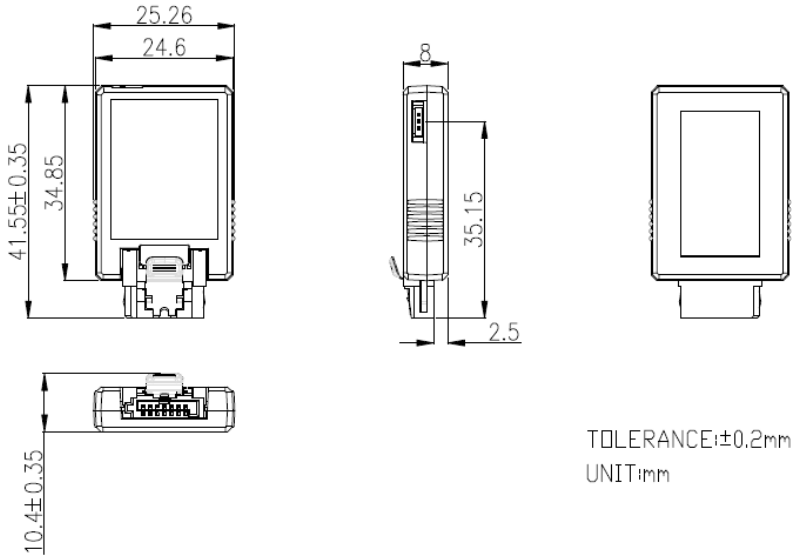

### Specifications

Interface	SATA III
Flash Type	iSLC
Capacity	8GB~64GB
Max. Channels	2
Sequential R/W (MB/sec, max.)	530/340
Max. Power Consumption	1.715W (5V x 343mA )
Thermal Sensor	√
Extended DRAM buffer	-
H/W Write Protect	√
ATA Security	√
S.M.A.R.T.	√
Dimension (WxLxH)	41.55 x 25.26 x 10.4 mm
Environment	Vibration: 20G @7~2000Hz Shock: 1500G @ 0.5ms Storage Temperature: -55°C ~ +95°C MTBF: 3 million hours

### Ordering Information

	8GB	16GB	32GB	64GB
Standard Grade (0°C ~ +70°C)	DHSMV-08GM41BC1DC*	DHSMV-16GM41BC1DC*	DHSMV-32GM41BC1DC*	DHSMV-64GM41BC1DC*
Industrial Grade (-40°C ~ +85°C)	DHSMV-08GM41BW1DC*	DHSMV-16GM41BW1DC*	DHSMV-32GM41BW1DC*	DHSMV-64GM41BW1DC*

\*=A-> Pin 8+ power cable

\*=B-> Pin 8+ Pin 7