

SATADOM-SL

3IE3 V2 series

Diagram

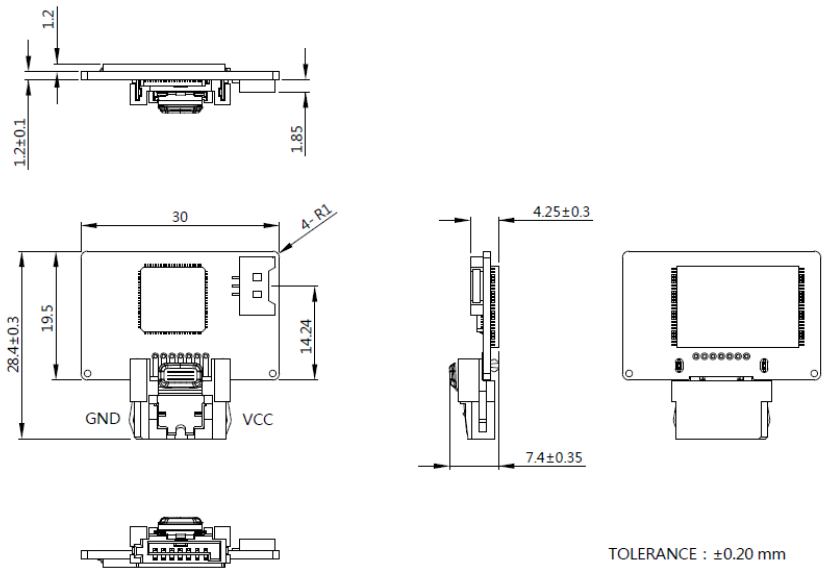

Specifications

Interface	SATA III
Flash Type	iSLC
Capacity	8GB~64GB
Max. Channels	2
Sequential R/W (MB/sec, max.)	230 / 110
Max. Power Consumption	0.8W (5V x 173mA)
Thermal Sensor	WT only
External DRAM buffer	-
H/W Write Protect	-
ATA Security	√
S.M.A.R.T.	√
Dimension (WxLxH)	30 X 28.4 X 7.4 mm
Environment	Vibration: 20G @7~2000Hz Shock: 1500G @ 0.5ms Storage Temperature: -55°C ~ +95°C MTBF: 3 million hours

Ordering Information

Operation Temp.	8GB	16GB	32GB	64GB
Standard Grade (0°C ~ +70°C)	DHSSL-08GD09BC1SC*	DHSSL-16GD09BC1SC*	DHSSL-32GD09BCADC*	DHSSL-64GD09BCADC*
Industrial Grade (-40°C ~ +85°C)	DHSSL-08GD09BW1SC*	DHSSL-16GD09BW1SC*	DHSSL-32GD09BWADC*	DHSSL-64GD09BWADC*

*=A-> Pin8+ power cable

*=B-> Pin8+ Pin 7