

SATADOM-SL

3IE4 series

Diagram

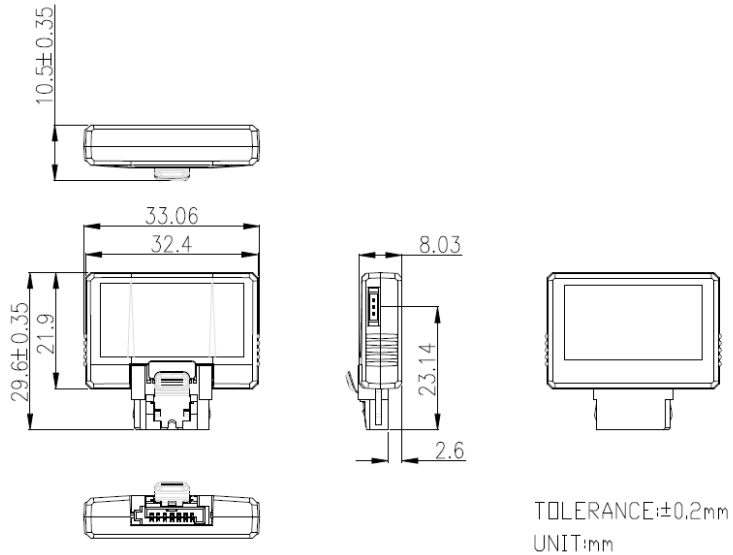

Specifications

Interface	SATA III
Flash Type	iSLC
Capacity	8GB~64GB
Max. Channels	2
Sequential R/W (MB/sec, max.)	530/350
Max. Power Consumption	1.33W (5Vx265.1mA)
Thermal Sensor	√
Extended DRAM buffer	-
H/W Write Protect	-
ATA Security	√
S.M.A.R.T.	√
Dimension (WxLxH)	33.06 x 29.6 x 10.5 mm
Environment	Vibration: 20G @7~2000Hz Shock: 1500G @ 0.5ms Storage Temperature: -55°C ~ +95°C MTBF: 3 million hours

Ordering Information

	8GB	16GB	32GB(1CH)	32GB(2CH)	64GB
Standard Grade (0°C ~ +70°C)	DHSSL-08GM41BC1SC*	DHSSL-16GM41BC1SC*	DHSSL-32GM41BC1SC*	DHSSL-32GM41BCADC*	DHSSL-64GM41BCADC*
Industrial Grade (-40°C ~ +85°C)	DHSSL-08GM41BW1SC*	DHSSL-16GM41BW1SC*	DHSSL-32GM41BW1SC*	DHSSL-32GM41BWADC*	DHSSL-64GM41BWADC*

*=A-> Pin 8+ power cable
*=B-> Pin 8+ Pin 7