

# mSATA

## 3IE2-P series

### Diagram

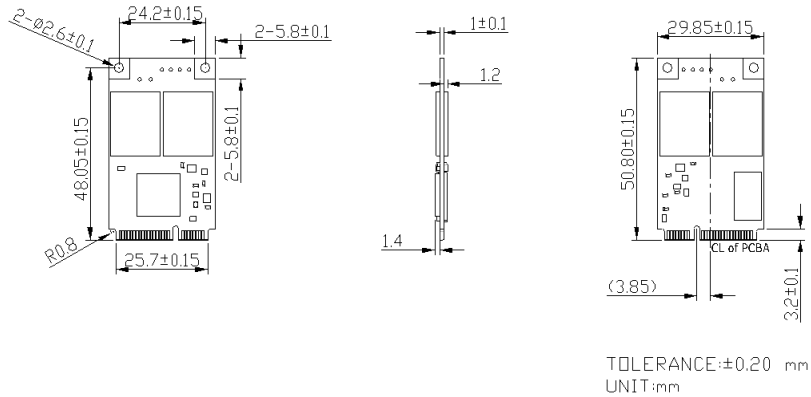

### Specifications

Interface	SATA III
Flash Type	MLC
Capacity	8GB~256GB
Max. Channels	4
Sequential R/W (MB/sec, max.)*	560 / 470
4KB Random (OD32) R/W (IOPS)**	51,000/46,000
Max. Power Consumption	2.8 W ( 3.3 V x 0.86 A )
Thermal Sensor	✓
External DRAM Buffer	✓
H/W Write Protect	Optional
ATA Security	✓
S.M.A.R.T.	✓
DEVSPL Mode	✓ (min. power consumption 3mW)
Slumber Mode	✓ (min. power consumption 30mW)
Dimension (WxLxH)	29.85 X 50.8 X 3.6 mm
Environment	Vibration: 20G @7~2000Hz Shock: 1500G @ 0.5ms Storage Temperature: -55°C ~ +95°C MTBF: 3 million hours
* Sequential performance based on CrystalDiskMark 3.01 with file size 1000MB	
** Random performance based on IOmeter with Queue Depth 32	

### Ordering Information

Operation Temp.	8GB	16GB	32GB	64GB	128GB	256GB
Standard Grade (0°C ~ +70°C)	DHMSR-08GD81BC1SC	DHMSR-16GD81BC1QC	DHMSR-32GD81BC1QC	DHMSR-64GD81BC1QC	DHMSR-A28D81BC1QC	DHMSR-B56D81BC1QC
Industrial Grade (-40°C ~ +85°C)	DHMSR-08GD81BW1SC	DHMSR-16GD81BW1QC	DHMSR-32GD81BW1QC	DHMSR-64GD81BW1QC	DHMSR-A28D81BW1QC	DHMSR-B56D81BW1QC