

# W15IAD3S-MRC3FP

15.6" Intel® Core™ i5-1335U Flat PCAP ECDIS Marine Panel PC



## KEY FEATURES

- 15.6" 1920 x 1080 PCAP touchscreen, Flat PCAP ECDIS Marine Panel PC
- 13th Gen. Intel® Core™ i5-1335U @ 3.4GHz
- Edge-to-edge narrow bezel design and fanless cooling system
- Capacitive touch keys for quick function access and display control (Support ECDIS DAY, DUSK, and NIGHT mode switching)
- Meet the requirements of Industrial marine standards, including IEC60945 4th Edition, DNV-CG-0339, IACS E10

## INTRODUCTION

Winmate ECDIS Marine Panel PC Series offers advanced functionality and reliability for maritime applications, available in sizes from 10.1" to 27". Designed with an edge-to-edge narrow bezel and a fanless cooling system, these panel PCs provide a sleek, durable solution for harsh marine environments. Featuring capacitive touch keys for quick function access, support for DAY, DUSK, and NIGHT mode switching, and optional NMEA 0183 protocol support, this series ensures seamless navigation and operational efficiency for marine vessels and control rooms.

## OVERVIEW

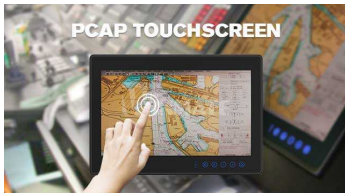

### 15.6" ECDIS Marine Panel PC with PCAP Touchscreen

The Winmate W15IAD3S-MRC3FP features a 15.6-inch Full HD (1920 x 1080) PCAP touchscreen, delivering exceptional clarity and responsiveness. Its flat front design ensures seamless integration into modern marine control systems, making it an ideal solution for ECDIS applications.

### Certified for Harsh Marine Conditions

Constructed to meet IEC60945 4th Edition, DNV-CG-0339, and IACS E10 standards, this marine panel PC is built for extreme maritime conditions. Its rugged durability and dependable operation make it the perfect choice for marine navigation and vessel management.





### Quick Access with Capacitive Touch Keys

With capacitive touch keys, users can easily control display functions and switch between ECDIS DAY, DUSK, and NIGHT modes. Operators can seamlessly adjust display settings for improved visibility and usability in different maritime conditions.

### Modern Design with Efficient Cooling

The narrow bezel design maximizes screen space while maintaining a compact and elegant appearance. Its fanless cooling system enhances system longevity by eliminating moving parts, ensuring silent and reliable operation in maritime and industrial settings.



## SPECIFICATIONS

### Display

<b>Touch / Glass</b>	Projected Capacitive Multi Touch Screen (AR Coating) AG film (Optional) AR Glass (Optional)	<b>Resolution</b>	1920x1080
<b>Size</b>	15.6 inches	<b>Contrast Ratio</b>	800:1
<b>Panel Brightness</b>	450.0 nits	<b>View Angles</b>	89,89,89,89
<b>Active Area</b>	344.16x193.59 mm		

### System Specification

<b>Processor</b>	Intel® Core™ i5-1335U 3.4GHz(up to 4.60 GHz)	<b>Memory</b>	1 x SO-DIMM, DDR5 4800 MHz, 8GB 16GB (Optional) 32GB (Optional)
<b>Storage</b>	1 x M.2 2280 M-Key NVMe SSD 128GB 256GB (Optional) 512GB (Optional) 1TB (Optional) 2TB (Optional)	<b>Ethernet controller</b>	2 x Intel® Ethernet Controller
<b>Operating System</b>	Windows 11 IoT Enterprise (64 bit) (Optional) Windows 11 Pro 64 bit (Optional) Windows 10 IoT Enterprise (64 bit) (Optional) Linux Ubuntu 22.04(Do not support Wake on Touch) (Optional)	<b>Buzzer</b>	75 dB~80 dB, 2300 Hz, 1m

### Environment

<b>Operating Humidity</b>	5% to 95%	<b>Operating Temperature</b>	-15~55°C
<b>Shock</b>	15G, 11ms duration	<b>Vibration</b>	0.7g@DNV-CG-0339 (Class A)
<b>IP rating</b>	IP66 (Front Side)		

### Certification

<b>Certification</b>	CE, FCC
----------------------	---------

### IO Ports

<b>USB Port</b>	2 x USB3.0	<b>Serial Port</b>	1 x RS232(Default)/422/485
<b>Video</b>	1 x HDMI (Optional)	<b>LAN</b>	2 x RJ45
<b>Front Control</b>	Power Brightness + Brightness - Menu Function Key(Default setting: ECDIS Mode)	<b>Indicator</b>	Day Mode Dusk Mode Night Mode
<b>DIDO</b>	8 Channel Isolated Digital Input/Output (Optional)	<b>NMEA</b>	4 x NMEA 0183 Port (Optional)

### Mechanical

<b>Dimension</b>	400 x 276 x 67 mm	<b>Weight</b>	6.8 kg
<b>Mounting</b>	VESA mount/Panel mount	<b>Enclosure</b>	Anodized Aluminum Bezel
<b>Cooling System</b>	Fanless Design	<b>Cut out</b>	378 x 254mm

### Accessory

<b>Accessory</b>	User Manual 12V AC to DC Adapter (with 3 pin Terminal Block) Power Cord M4 x 30 Black Screws Bolts M4 x 15 Silver Screws Bolts	<b>Optional Accessory</b>	Four 5 Pin Terminal Block 3.81 (Phoenix Type)*For NMEA port (Optional)
------------------	--	---------------------------	--

### Power

<b>Power Rating</b>	24V DC-in with Isolation (Approval by Certificate) 9~36V DC Input Acceptable	<b>Consumption</b>	60W (Typical)
---------------------	---	--------------------	---------------

**DIMENSIONS** UNIT:MM

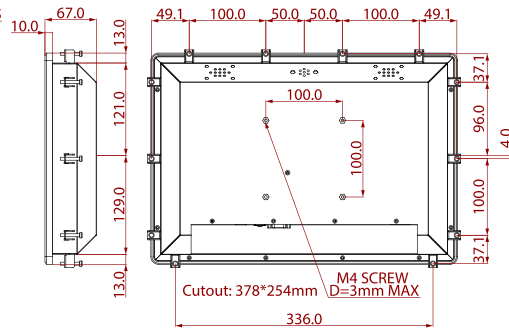
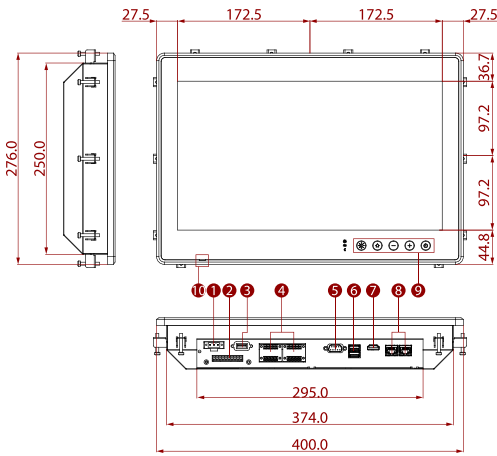
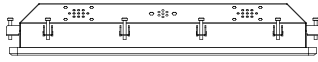

- 1 Power Input
- 2 DIDO (Optional)
- 3 USB Type-A (Optional)
- 4 NMEA Port 0183 (Optional)
- 5 COM
- 6 USB Type-A
- 7 HDMI
- 8 LAN
- 9 OSD Control Panel
- 10 Buzzer

**NOTE**

1. This is a simplified drawing and some components are not marked in detail.
2. Only 24 V DC has been approved by DNV certification.
3. Please contact our sales representative if you need further product information.
4. All specifications are subject to change without prior notice.
5. The product shown in this datasheet is a standard model. For diagrams that contain customized or optional I/O, please contact the Winmate Sales Team for more information.